

# SCIENCE/ENGINEERING PHYSICS TEST

## CHAPTER 12 - SIMPLE HARMONIC MOTION - 100 PTS 1994-95

**ALL STUDENTS MUST DO THE FOLLOWING PROBLEM!**

1. A spring is hung vertically from a support. A mass of 4.50 kg is hung from the lower end of the spring and is slowly lowered a distance of 22.0 cm until equilibrium is reached. This mass is then lowered to a point 15.0 cm below the equilibrium point and is then released, after which the mass vibrates up and down in simple harmonic motion. This mass vibrates until after 200 cycles the mass oscillates to a maximum displacement of 10.0 cm from the equilibrium point. Assuming that  $t = 0$  just as the mass is released from the point 15.0 cm below the equilibrium point and that zero potential energy occurs at the equilibrium position, determine; [Note that these questions may not be calculated in the order in which they appear!] [30 pts total]
  - a. the **spring constant** for this spring? [2 pts]
  - b. the **period** of oscillation of this system? [2 pts]
  - c. the **angular velocity** of this system? [2 pts]
  - d. the **position** of this mass 25.0 seconds after the mass has been released? [2 pts]
  - e. the initial **mechanical energy** contained in this system? [2 pts]
  - f. the percentage of **energy lost** by this system during each cycle? [2 pts]
  - g. the **energy remaining** in this system after 150 cycles? [2 pts]
  - h. the **amplitude** of this system after completing 150 cycles? [2 pts]
  - i. the **time constant** for this system? [2 pts]
  - j. the **quality factor** for this system? [2 pts]
  - k. the **maximum velocity** of this system during the first cycle? [2 pts]
  - l. the **velocity** of the system 25.0 seconds after the mass has been released? [2 pts]
  - m. the **maximum acceleration** of this system during the hundredth cycle? [2 pts]
  - n. the **time** required for the maximum amplitude of the vibration to be reduced to 2.50 cm.? [2 pts]
  - o. the **number of cycles** required for the energy of the system to be reduced to 1.0 % of its initial value? [2 pts]

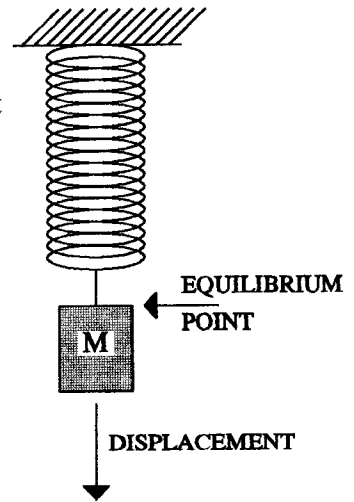

**OF THE FOLLOWING PROBLEMS YOU MUST DO 2**

2. A C clamp oscillates on the end of a meter stick which is clamped to a lab table as shown to the right. When a force of 16.5 N is applied to the end of the meterstick it is displaced a distance of 8.00 cm. After being released the end of the meterstick oscillates with a period of 0.7854 seconds and after ten oscillations the displacement of the end of the meterstick is reduced to 3.0 cm. This system is driven by a sinusoidal driving force supplied by a string attached to a rotating disc. The maximum force applied by the driving force is 1.50 N and the initial angular velocity of the disc is  $\omega = 7.55$  Rad/sec.
  - a. What is the **quality factor** of this system? [5 pts]
  - b. What will be the **maximum amplitude** of this system while being driven by the external driving force? [5 pts]
  - c. If the driving force is varied, at what **frequency** will resonance occur? [5 pts]
  - d. What will be the **amplitude** of the oscillations at resonance? [5 pts]
  - e. How much **energy** is being added to this system by the driving force during each cycle? [5 pts]
  
3. A metal ring has a mass of  $m = 1.75$  kg and a radius of  $R = 50$  cm. This ring is pivoted about a point as shown in the diagram to the right. The bottom edge of the ring is displaced to the right a distance of 8.2 centimeters, as shown, and is then released.
  - a. What is the **moment of inertia** of this ring about the given center of rotation? [5 pts]
  - b. What will be the **period of oscillation** of this ring? [5 pts]
  - c. What will be the **displacement** of the center of mass of this ring 1.80 seconds after the ring is released? [5 pts]
  - d. What will be the **velocity** of the center of mass of this ring 1.80 seconds after the plate is released? [5 pts]
  - e. How much **work** was done in setting this oscillator into motion? [5 pts]

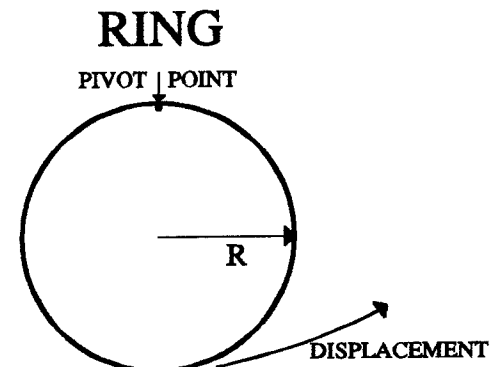
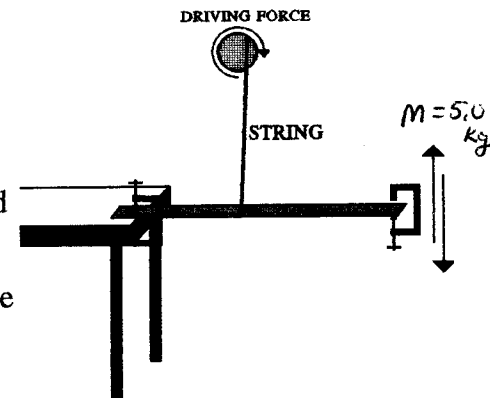

4. A mass  $M_1 = 1.85 \text{ kg}$  rests on a horizontal table which has a coefficient of kinetic friction of  $\mu = 0.0045$ . This mass is connected to a horizontally mounted spring which has a spring constant of  $k = 450 \text{ N/m}$ . The spring is initially unstretched. A second mass  $M_2 = 2.75 \text{ kg}$  is connected to  $M_1$  by a non-stretching, massless string that passes over a frictionless, massless pulley. When the masses are released the system executes simple harmonic motion.

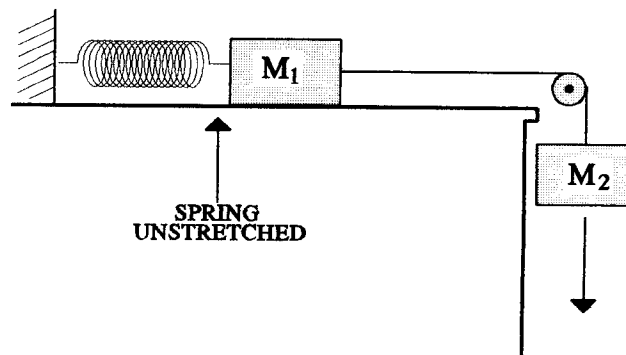

- What will be the resulting period of vibration of this system? [5 pts]
- What will be the maximum amplitude of the resulting SHM? [5 pts]
- What will be the maximum linear velocity of this system? [5 pts]
- What will be the total mechanical energy of this system relative to the equilibrium position? [5 pts]
- What percentage of the total energy will be lost during each cycle? [5 pts]

**ALL STUDENTS MUST DO THE FOLLOWING MULTIPLE CHOICE PROBLEMS FOR EACH QUESTION SELECT ALL APPROPRIATE ANSWERS. [4 POINTS EACH]**

- Which of the following statements could be used to describe the quality factor of a simple harmonic oscillator?
  - A measure of the total displacement of a simple harmonic oscillator.
  - A measure of the relative acceleration of a simple harmonic oscillator.
  - A measure of the rate at which energy is lost by a simple harmonic oscillator.
  - A measure of the damping effect on a simple harmonic oscillator.
  - A measure of the sharpness of the resonance of a forces simple harmonic oscillator.
- A given simple harmonic oscillator has an amplitude of  $A$  and an energy content of  $E$ . What will be the energy content of a corresponding simple harmonic oscillator that has an amplitude of  $4A$ ?
 

A.  $E$     B.  $2E$     C.  $3E$     D.  $9E$     E.  $12E$     F.  $16E$
- Resonance occurs in a simple harmonic oscillator when:
  - the external force has an amplitude greater than the amplitude of the simple harmonic oscillator
  - the angular acceleration of the simple harmonic oscillator is  $180^\circ$  out of phase with with the acceleration of the driving force.
  - the quality factor of the driving force is high and the quality factor of the simple harmonic oscillator is low.
  - the maximum velocity of the driving force is slightly greater than the maximum velocity of the simple harmonic oscillator.
  - the damping coefficient is small and the angular frequency of the driving force matches the angular frequency of the simple harmonic oscillator.
- The period of a simple pendulum depends primarily upon:
  - the maximum amplitude of the initial displacement of the pendulum.
  - the length of the pendulum.
  - the arc length of the pendulum's motion.
  - the mass of the pendulum bob.
  - all of the above factors.
  - none of the above factors.
- A simple harmonic oscillator consists of a mass  $M$  oscillating on the end of a spring, which has a spring constant  $k$ , with an amplitude  $A$  [friction is negligible!]. The mass on the end of the spring is **increased** to  $2M$ . Which of the following characteristics of the oscillator will likewise be **increased** by this change in mass?
 

A. amplitude    B. frequency    C. quality factor    D. period    E. angular velocity    F. All of these

1.  $M := 4.5 \cdot \text{kg}$     $x_{\text{eq}} := 0.22 \cdot \text{m}$     $A_0 := -0.15 \cdot \text{m}$     $A_{200} := 0.10 \cdot \text{m}$     $N := \text{newton}$

$J := \text{joule}$

a.  $k := \frac{M \cdot g}{x_{\text{eq}}}$     $k = 200.591 \cdot \frac{\text{N}}{\text{m}}$    **1a. The spring constant. [2 pts]**

b.  $T := 2 \cdot \pi \cdot \sqrt{\frac{M}{k}}$     $T = 0.941 \cdot \text{sec}$    **1b. The period of the SHM oscillator. [2 pts]**

c.  $\omega := \frac{2 \cdot \pi}{T}$     $\omega = 6.677 \cdot \frac{\text{rad}}{\text{sec}}$    **1c. The angular velocity of the system. [2 pts]**

$t := 25 \cdot \text{sec}$     $t_c := 1000 \cdot \text{sec}$

GIVEN  $A_{200} = A_0 \cdot \exp\left(-\frac{T \cdot 200}{2 \cdot t_c}\right)$     $t_c := \text{FIND}(t_c)$     $t_c = 232.1 \cdot \text{sec}$

d.  $A := A_0 \cdot \cos(\omega \cdot t) \cdot \exp\left(-\frac{t}{2 \cdot t_c}\right)$     $A = 0.1305 \cdot \text{m}$    **1d. The displacement at the end of 25 seconds. [2 pts]**

e.  $E_0 := \frac{1}{2} \cdot k \cdot A_0^2$     $E_0 = 2.257 \cdot \text{J}$    **1e. The initial energy of this system. [2 pts]**

f.  $E_1 := E_0 \cdot \exp\left(-\frac{T}{t_c}\right)$     $E_1 = 2.248 \cdot \text{J}$

$E_{\%} := \left(\frac{E_0 - E_1}{E_0}\right)$     $E_{\%} = 0.40464 \cdot \%$    **1f. Percentage of energy lost each cycle. [2 pts]**

g.  $E_{150} := E_0 \cdot \exp\left(-\frac{T \cdot 150}{t_c}\right)$     $E_{150} = 1.228 \cdot \text{J}$    **1g. The energy remaining after 150 cycles. [2 pts]**

h.  $A_{150} := |A_0| \cdot \exp\left(-\frac{T \cdot 150}{2 \cdot t_c}\right)$     $A_{150} = 0.111 \cdot \text{m}$    **1h. Maximum amplitude after 150 cycles. [2 pts]**

i.  $t_c = 232.101 \cdot \text{sec}$    **1i. The time constant for this system. [2 pts]**

j.  $Q := 2 \cdot \pi \cdot \left(\frac{E_0}{E_0 - E_1}\right)$     $Q = 1.553 \cdot 10^3$    **1j. The quality factor for this system. [2 pts]**

k.  $v_{\text{max}} := |A_0 \cdot \omega|$     $v_{\text{max}} = 1.001 \cdot \frac{\text{m}}{\text{sec}}$    **1k. Maximum velocity during the first cycle. [2 pts]**

l.  $v_{25\text{sec}} := -A_0 \cdot \omega \cdot \exp\left(-\frac{t}{2 \cdot t_c}\right) \cdot \sin(\omega \cdot t)$     $v_{25\text{sec}} = -0.377 \cdot \frac{\text{m}}{\text{sec}}$    **1l. The velocity of this system when  $t = 25 \text{ sec}$ . [2 pts]**

m.  $a_{\text{max}100} := A_0 \cdot \omega^2 \cdot \exp\left(-\frac{T \cdot 100}{2 \cdot t_c}\right)$     $a_{\text{max}100} = -5.459 \cdot \frac{\text{m}}{\text{sec}^2}$    **1m. The maximum acceleration during the hundredth cycle. [2 pts]**

1. [cont]

n.  $A_t := .025 \cdot m$   $t := 100 \cdot \text{sec}$  GIVEN  $A_t = |A_0| \cdot \exp\left(-\frac{t}{2 \cdot t_c}\right)$

$t := \text{FIND}(t)$   $t = 831.739 \cdot \text{sec}$  **1n. Time required for the amplitude to be reduced to 2.5 cm. [2 pts]**

o.  $E_{\text{final}} := .01 \cdot E_0$   $E_{\text{final}} = 0.023 \cdot J$   $n := 1$   $\frac{E_1}{E_0} = 0.996$

GIVEN  $E_{\text{final}} = E_0 \cdot \left(\frac{E_1}{E_0}\right)^n$

$n := \text{FIND}(n)$   $n = 1.136 \cdot 10^3$  **1o. The number of cycles required to reduce the energy to 1% of the initial value. [2 pts]**

2.  $F_0 := 16.5 \cdot N$   $d_0 := .080 \cdot m$   $T_0 := 0.7854 \cdot \text{sec}$   $d_{10} := 0.030 \cdot m$   $F_d := 1.50 \cdot N$   $\omega_d := 7.55 \cdot \frac{\text{rad}}{\text{sec}}$   $M := 5.0 \cdot \text{kg}$

a.  $t_c := 1 \cdot \text{sec}$  GIVEN  $d_{10} = d_0 \cdot \exp\left(-\frac{10 \cdot T_0}{2 \cdot t_c}\right)$   $t_c := \text{FIND}(t_c)$   $t_c = 4.00375 \cdot \text{sec}$

$Q := 2 \cdot \pi \cdot \frac{t_c}{T_0}$   $Q = 32.03$  **2a. The quality factor of this oscillator. [5 pts]**

b.  $\omega_0 := \frac{2 \cdot \pi}{T_0}$   $\omega_0 = 7.99998 \cdot \frac{\text{rad}}{\text{sec}}$   $b := \frac{M}{t_c}$   $b = 1.249 \cdot \frac{\text{kg}}{\text{sec}}$

$A_{\text{max}} := \frac{F_d}{\sqrt{M^2 \cdot (\omega_0^2 - \omega_d^2)^2 + b^2 \cdot \omega_d^2}}$   $A_{\text{max}} = 0.0414 \cdot m$  **2b. Maximum amplitude at driven angular frequency. [5 pts]**

c.  $\omega_0 = 7.99998 \cdot \frac{\text{rad}}{\text{sec}}$  **2c. Resonance will occur when the driving frequency matches the natural frequency of the oscillator. [5 pts]**

d.  $\omega_d := \omega_0$   $\omega_d = 7.99998 \cdot \frac{\text{rad}}{\text{sec}}$

$A_{\text{max}} := \frac{F_d}{\sqrt{M^2 \cdot (\omega_0^2 - \omega_d^2)^2 + b^2 \cdot \omega_d^2}}$   $A_{\text{max}} = 0.1501 \cdot m$  **2d. Maximum amplitude at resonance. [5 pts]**

e. **SINCE**  $Q = 2 \cdot \pi \cdot \left(\frac{E}{\Delta E}\right)$  **the amount lost each cycle  $\Delta E$  must equal the replaced by the driving force.**

**therefore**  $\Delta E := \frac{E_0 \cdot 2 \cdot \pi}{Q}$   $\Delta E = 0.443 \cdot J$  **2e. The energy replaced each cycle. [5 pts]**

3.  $m_{\text{ring}} := 1.75 \cdot \text{kg}$   $R_{\text{ring}} := 50.0 \cdot \text{cm}$   $A_0 := 8.2 \cdot \text{cm}$

a.  $I := m_{\text{ring}} \cdot R_{\text{ring}}^2 + m_{\text{ring}} \cdot R_{\text{ring}}^2$   $I = 0.875 \cdot \text{kg} \cdot \text{m}^2$  **3a. Moment of inertia. [5 pts]**

b.  $T := 2 \cdot \pi \cdot \sqrt{\frac{I}{m_{\text{ring}} \cdot g \cdot R_{\text{ring}}}}$   $T = 2.006 \cdot \text{sec}$  **3b. The period of this compound pendulum [5 pts]**

c.  $t := 1.80 \cdot \text{sec}$   $\omega := \frac{2 \cdot \pi}{T}$   $A := \frac{A_0 \cdot \cos(\omega \cdot t)}{2}$   $A = 0.033 \cdot \text{m}$  **3c. Displacement of the center of mass when  $t = 1.80$  sec. [5 pts]**

d.  $v := \frac{-A_0 \cdot \omega \cdot \sin(\omega \cdot t)}{2}$   $v = 0.077 \cdot \frac{\text{m}}{\text{sec}}$  **3d. The velocity of the center of mass when  $t = 1.80$  sec. [5 pts]**

e.  $\theta := \text{asin}\left(\frac{A_0}{R_{\text{ring}}}\right)$   $\theta = 9.439 \cdot \text{deg}$   $\Delta h := R_{\text{ring}} \cdot (1 - \cos(\theta))$   $\Delta h = 0.00677 \cdot \text{m}$

$\text{Work} := m_{\text{ring}} \cdot g \cdot \Delta h$   $\text{Work} = 0.116 \cdot \text{J}$  **3e. The work done in starting this compound pendulum into motion. [5 pts]**

4.  $M_1 := 1.85 \cdot \text{kg}$   $\mu := 0.0045$   $k := 450 \cdot \frac{\text{N}}{\text{m}}$   $M_2 := 2.75 \cdot \text{kg}$

a.  $T := 2 \cdot \pi \cdot \sqrt{\frac{M_1 + M_2}{k}}$   $T = 0.635 \cdot \text{sec}$  **4a. The period of oscillation of this system. [5 pts]**

b.  $x := 1 \cdot \text{m}$

GIVEN  $\frac{1}{2} \cdot k \cdot x^2 = M_2 \cdot g \cdot x$   $x := \text{FIND}(x)$   $x = 0.11986 \cdot \text{m}$

c.  $\omega := \frac{2 \cdot \pi}{T}$   $\omega = 9.891 \cdot \frac{\text{rad}}{\text{sec}}$   $A_0 := \frac{x}{2}$   $A_0 = 0.0599 \cdot \text{m}$  **4b. The maximum amplitude of the oscillations. [5 pts]**

$v_{\text{max}} := A_0 \cdot \omega$   $v_{\text{max}} = 0.593 \cdot \frac{\text{m}}{\text{sec}}$  **4c. The maximum velocity of this oscillator. [5 pts]**

d.  $\text{Total energy} := M_2 \cdot g \cdot A_0$   $\text{Total energy} = 1.616 \cdot \text{J}$  **4d. The total energy of the system. [4 pts]**

$\text{TE} := \frac{1}{2} \cdot k \cdot A_0^2$   $\text{TE} = 0.808 \cdot \text{J}$  **[Using EPE!]**

e.  $F_f := M_1 \cdot g \cdot \mu$   $E_{\text{lost}} := 2 \cdot F_f \cdot x$   $E_{\text{lost}} = 0.01957 \cdot \text{J}$

$\% \text{ energylost} := \frac{E_{\text{lost}}}{\text{TE}}$   $\% \text{ energylost} = 2.422 \cdot \%$  **4e. Percent energy lost per cycle. [5 pts]**

5. C,D,E

8. B

6. F

Multiple choice 4 pts each!

9. A,D,C

7. E